

Mini-Bars Type 080... for Internal Back Turning

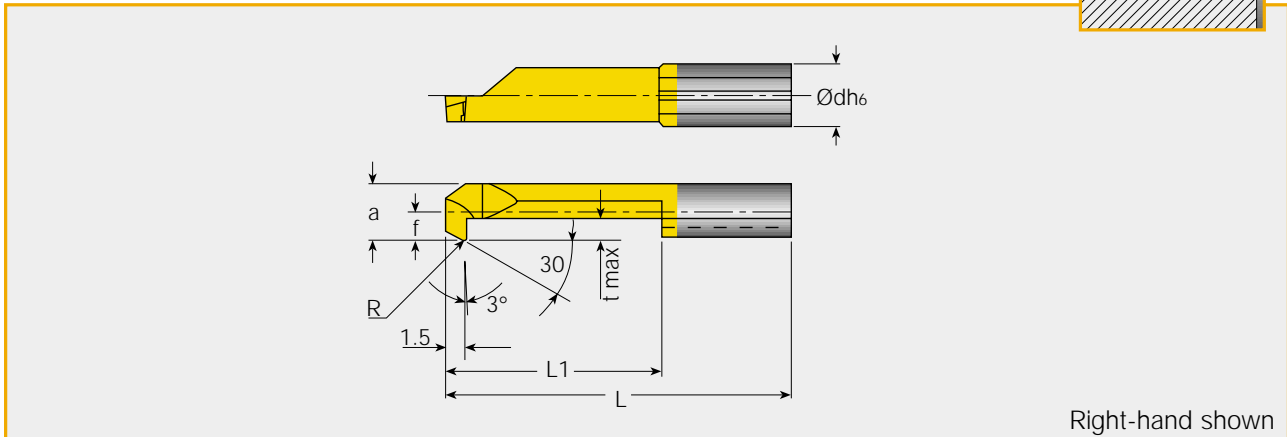
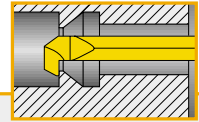

PICCO 080...

Designation	$\varnothing dh_6$	f	a	L	L_1	$R^{+0.05}$	t max.	Min. Bore Dia.	HOLDERS
PICCO R/L 080.0003-15	4.0	0.6	2.6	29	14	0.10	0.5	3.0	
PICCO R/L 080.0003-20	4.0	0.6	2.6	34	19	0.10	0.5	3.0	
PICCO R/L 080.0004-15	4.0	1.5	3.5	29	14	0.15	0.8	4.0	PICCO 12-4-5 PICCO 16-4-5 PICCO 20-4-5
PICCO R/L 080.0004-25	4.0	1.5	3.5	39	24	0.15	0.8	4.0	
PICCO R/L 080.0005-20	5.0	1.9	4.4	35	19	0.20	1.0	5.0	
PICCO R/L 080.0005-30	5.0	1.9	4.4	45	29	0.20	1.0	5.0	
PICCO R/L 080.0006-20	6.0	2.3	5.3	35	19	0.20	1.8	6.0	MG PCO 12-6 ⁽¹⁾ MG PCO 16-6-8 ⁽¹⁾ MG PCO 20-6-8 ⁽¹⁾
PICCO R/L 080.0006-30	6.0	2.3	5.3	45	29	0.20	1.8	6.0	
PICCO R/L 080.0007-20	7.0	2.7	6.3	35	19	0.20	2.5	7.0	
PICCO R/L 080.0007-30	7.0	2.7	6.3	45	29	0.20	2.5	7.0	PICCO 16-6-7 PICCO 20-6-7

Specify right- or left-hand bars.

Carbide grades of bars are IC28 and PVD coated IC228.

For holders, see ISCAR Turning Tools catalog.

⁽¹⁾ For $\varnothing 6$ mm only.

Mini-Bars Type 050... for 0.6 mm Diameter Boring

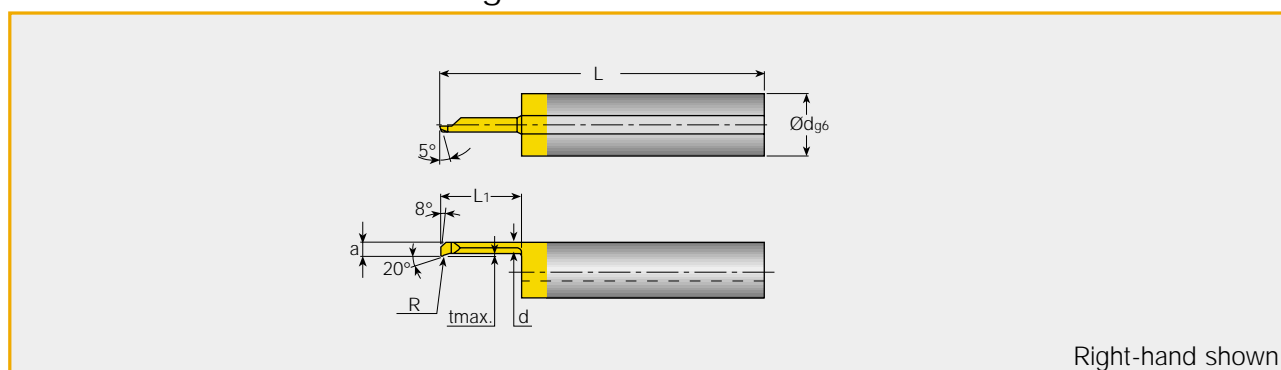

PICCO 050...

Designation	$\varnothing d_{h6}$	a	L	L_1	$R^{+0.05}$	t max.	Min. Bore Dia.	Holders
PICCO R/L 050.06-2	4.0	0.5	20	2.0	0.04	0.08	0.6	PICCO 12-4-5
PICCO R/L 050.06-3	4.0	0.5	20	3.0	0.04	0.08	0.6	PICCO 16-4-5 PICCO 20-4-5

Available grade: IC228

For holders, see ISCAR Turning Tools catalog.

D.O.C. = 0.01-0.03 mm

Feed = 0.01 mm/rev

Mini-Bars Type 050... For Internal Turning and Chamfering

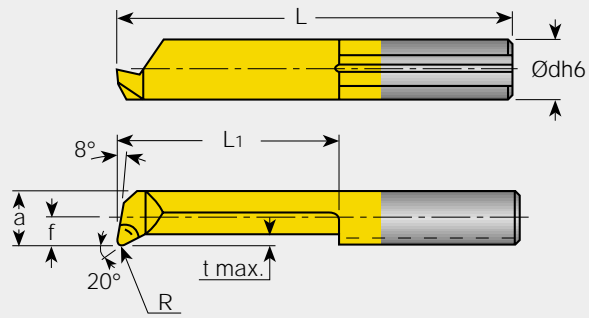
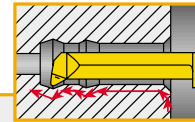

Right-hand shown

PICCO 050...

Designation	Ødh6	f	a	L	L ₁	R ^{+0.05}	t max.	Min Bore Dia.	Holders
PICCO R/L 050.4-24	4.0	1.5	3.5	38	23	0.10	0.3	4.0	PICCO 12-4-5
PICCO R/L 050.4-28	4.0	1.5	3.5	42	27	0.10	0.3	4.0	PICCO 16-4-5
PICCO R/L 050.5-35	5.0	1.9	4.4	50	34	0.15	0.5	5.0	PICCO 20-4-5
PICCO R/L 050.6-35	6.0	2.3	5.3	50	34	0.15	0.5	6.0	MG PCO 12-6- ⁽¹⁾
PICCO R/L 050.6-42	6.0	2.3	5.3	57	41	0.15	0.5	6.0	MG PCO 16-6-8- ⁽¹⁾
PICCO R/L 050.7-35	7.0	2.8	6.3	50	34	0.15	0.6	7.0	MG PCO 20-6-8- ⁽¹⁾
PICCO R/L 050.7-40	7.0	2.8	6.3	55	39	0.15	0.6	7.0	PICCO 16-6-7
PICCO R/L 050.7-45	7.0	2.8	6.3	60	44	0.15	0.6	7.0	PICCO 20-6-7
PICCO R/L 050.7-50	7.0	2.8	6.3	65	49	0.15	0.6	7.0	

Specify right-or left-hand bars. Carbide grades of bars are IC28 and PVD coated IC228.
For holders see ISCAR Turning Tools catalog.

⁽¹⁾ For Ø6mm only.