

Mini-Bars Type 080... for Internal Back Turning

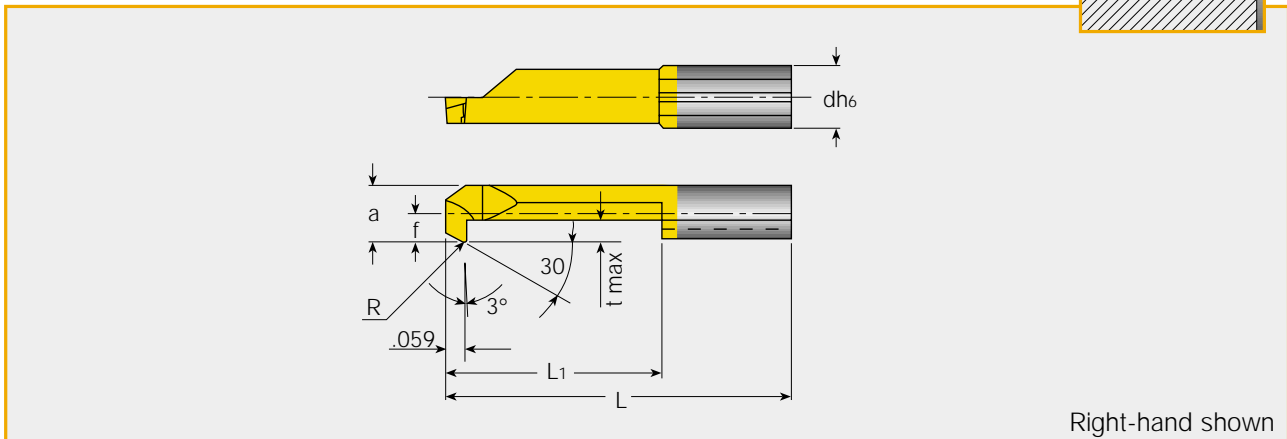
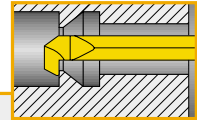

PICCO 080...

Designation	$\varnothing dh_6$	f	a	L	L_1	R ^{+.002}	t max.	Min. Bore Dia.	HOLDERS
PICCO R/L 080.0003-15	.157	.024	.102	1.142	.551	.004	.020	.118	PICCO 12.7-4-5 PICCO 15.9-4-5 PICCO 19-4-5
PICCO R/L 080.0003-20	.157	.024	.102	1.339	.748	.004	.020	.118	
PICCO R/L 080.0004-15	.157	.059	.138	1.142	.551	.006	.031	.157	
PICCO R/L 080.0004-25	.157	.059	.138	1.535	.945	.006	.031	.157	
PICCO R/L 080.0005-20	.197	.075	.173	1.378	.748	.008	.039	.197	PICCO 15.9-6-7 PICCO 19-6-7
PICCO R/L 080.0005-30	.197	.075	.173	1.772	1.142	.008	.039	.197	
PICCO R/L 080.0006-20	.236	.091	.209	1.378	.748	.008	.071	.236	PICCO 15.9-6-7 PICCO 19-6-7
PICCO R/L 080.0006-30	.236	.091	.209	1.772	1.142	.008	.071	.236	
PICCO R/L 080.0007-20	.276	.106	.248	1.378	.748	.008	.098	.276	PICCO 15.9-6-7 PICCO 19-6-7
PICCO R/L 080.0007-30	.276	.106	.248	1.772	1.142	.008	.098	.276	

Specify right- or left-hand bars.

Carbide grades of bars are IC28 and PVD coated IC228.

For holders, see ISCAR Turning Tools catalog.

(1) For .0236 inch only.

Mini-Bars Type 050...
for .0236" Diameter Boring

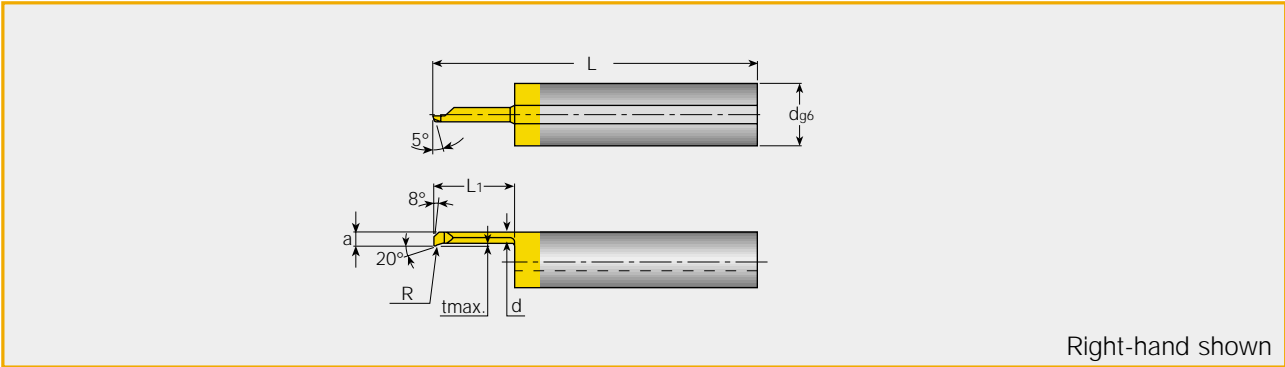

PICCO 050...

Designation	$\varnothing dh6$	a	L	L ₁	R ^{+.002}	t max.	Min. Bore Dia.	Holders
PICCO R/L 050.06-2	.157	.0197	.787	.0787	.0016	.0031	.0236	PICCO 12.7-4-5
PICCO R/L 050.06-3	.157	.0197	.787	.118	.0016	.0031	.0236	PICCO 15.9-4-5 PICCO 19-4-5

Available grade: IC228

For holders, see ISCAR Turning Tools catalog.

D.O.C. = .0004"-.0012"

Feed = .0004 inch/rev

Mini-Bars Type 050...
For Internal Turning and Chamfering

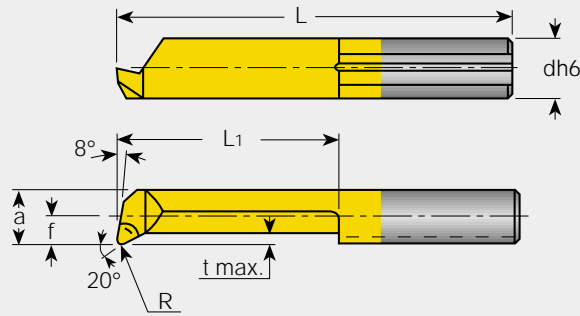
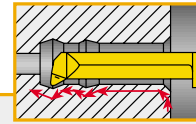

Right-hand shown

PICCO 050...

Designation	ødh6	f	a	L	L ₁	R+.002	t max.	Min Bore Dia.	Holders
PICCO R/L 050.4-24	.157	.059	.138	1.496	.906	.004	.0118	.157	PICCO 12.7-4-5
PICCO R/L 050.4-28	.157	.059	.138	1.654	1.063	.004	.0118	.157	PICCO 15.9-4-5
PICCO R/L 050.5-35	.197	.075	.173	1.968	1.339	.006	.0197	.197	PICCO 19-4-5
PICCO R/L 050.6-35	.236	.091	.209	1.968	1.339	.006	.0197	.236	MG PCO 9.5-6 ⁽¹⁾
PICCO R/L 050.6-42	.236	.091	.209	2.244	1.614	.006	.0197	.236	MG PCO 12.7-6 ⁽¹⁾
PICCO R/L 050.7-35	.276	.110	.248	1.968	1.339	.006	.0236	.276	MG PCO 15.9-6-8 ⁽¹⁾
PICCO R/L 050.7-40	.276	.110	.248	2.165	1.535	.006	.0236	.276	MG PCO 19-6-8 ⁽¹⁾
PICCO R/L 050.7-45	.276	.110	.248	2.362	1.732	.006	.0236	.276	PICCO 15.9-6-7
PICCO R/L 050.7-50	.276	.110	.248	2.559	1.929	.006	.0236	.276	PICCO 19-6-7

Specify right-or left-hand bars. Carbide grades of bars are IC28 and PVD coated IC228.
For holders see ISCAR Turning Tools catalog.

⁽¹⁾ For .236" only.