

Mini-Barras Tipo 080... para Mandrinado en Retroceso



Figura a derechas

PICCO 080...

Denominación	$\varnothing dh_6$	f	a	L	L_1	$R^{+0.05}$	t m \acute{a} x.	\varnothing M \acute{i} n. Agujero Portahtas.
PICCO R/L 080.0003-15	4.0	0.6	2.6	29	14	0.10	0.5	3.0
PICCO R/L 080.0003-20	4.0	0.6	2.6	34	19	0.10	0.5	3.0
PICCO R/L 080.0004-15	4.0	1.5	3.5	29	14	0.15	0.8	4.0
PICCO R/L 080.0004-25	4.0	1.5	3.5	39	24	0.15	0.8	4.0
PICCO R/L 080.0005-20	5.0	1.9	4.4	35	19	0.20	1.0	5.0
PICCO R/L 080.0005-30	5.0	1.9	4.4	45	29	0.20	1.0	5.0
PICCO R/L 080.0006-20	6.0	2.3	5.3	35	19	0.20	1.8	6.0
PICCO R/L 080.0006-30	6.0	2.3	5.3	45	29	0.20	1.8	6.0
PICCO R/L 080.0007-20	7.0	2.7	6.3	35	19	0.20	2.5	7.0
PICCO R/L 080.0007-30	7.0	2.7	6.3	45	29	0.20	2.5	7.0

Especificar barra a derechas o a izquierdas.

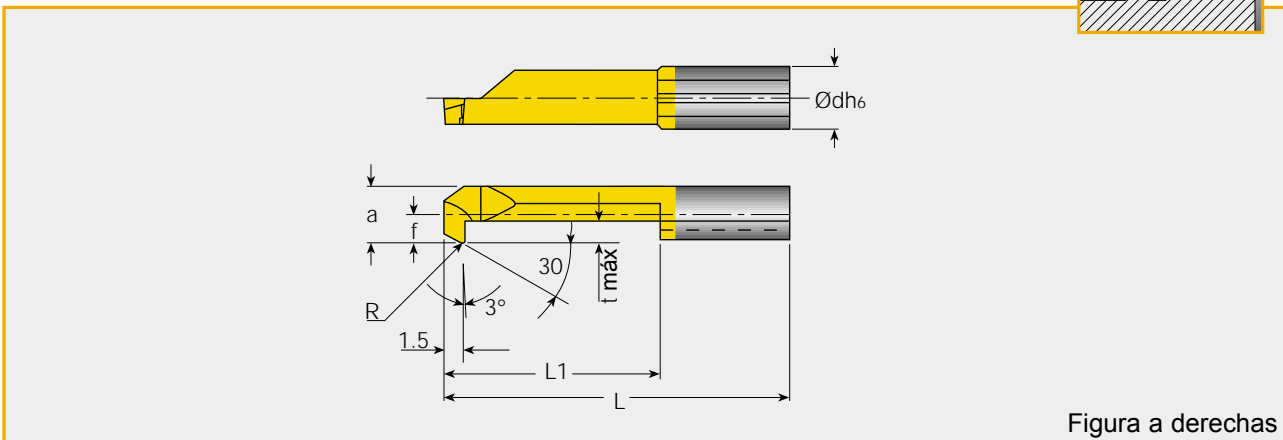
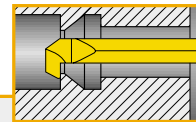
(1) S \acute{o} lo para $\varnothing 6$ mm.

Las calidades de las barras son IC28 y IC228 con recubrimiento PVD.

Para portaherramientas, ver el cat \acute{a} logo ISCAR Turning Tools.

Mini-Barras Tipo 050... para Agujeros de Diámetro de 0.6 mm



Figura a derechas

PICCO 050...

Denominación	Ødh6	a	L	L ₁	R ^{+0.05}	t máx.	Ø Mín. Agujero Portahtas.
PICCO R/L 050.06-2	4.0	0.5	20	2.0	0.04	0.08	0.6
PICCO R/L 050.06-3	4.0	0.5	20	3.0	0.04	0.08	0.6

Calidad disponible: IC228

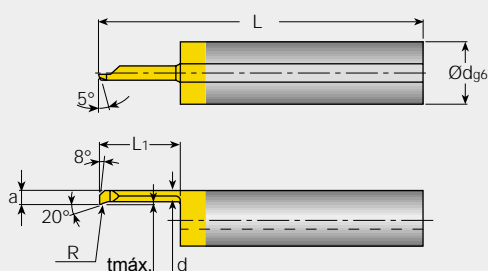
Para portaherramientas, ver el catálogo ISCAR Turning Tools.

Profundidad de corte = 0.01-0.03 mm

Avance = 0.01 mm/v

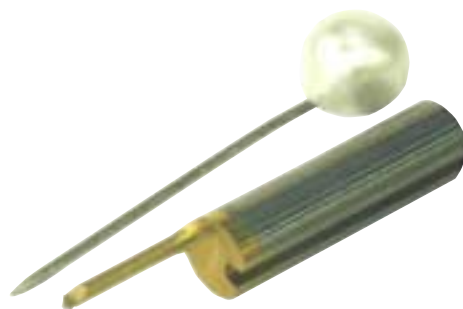

Mini-Barras Tipo 050... Para Torneado y Chaflanado Interior



Figura a derechas

PICCO 050...

Denominación	Ødh6	f	a	L	L ₁	R+0.05	t máx.	Ø Mín. Agujero Portahtas.	
PICCO R/L 050.4-24	4.0	1.5	3.5	38	23	0.10	0.3	4.0	PICCO 12-4-5
PICCO R/L 050.4-28	4.0	1.5	3.5	42	27	0.10	0.3	4.0	PICCO 16-4-5
PICCO R/L 050.5-35	5.0	1.9	4.4	50	34	0.15	0.5	5.0	PICCO 20-4-5
PICCO R/L 050.6-35	6.0	2.3	5.3	50	34	0.15	0.5	6.0	MG PCO 12-6 ⁽¹⁾
PICCO R/L 050.6-42	6.0	2.3	5.3	57	41	0.15	0.5	6.0	MG PCO 16-6-8 ⁽¹⁾
PICCO R/L 050.7-35	7.0	2.8	6.3	50	34	0.15	0.6	7.0	MG PCO 20-6-8 ⁽¹⁾
PICCO R/L 050.7-40	7.0	2.8	6.3	55	39	0.15	0.6	7.0	PICCO 16-6-7
PICCO R/L 050.7-45	7.0	2.8	6.3	60	44	0.15	0.6	7.0	PICCO 20-6-7
PICCO R/L 050.7-50	7.0	2.8	6.3	65	49	0.15	0.6	7.0	

Especificar barras a derechas o a izquierdas. Las calidades de las barras son IC28 IC228 con recubrimiento PVD.
Para portaherramientas, ver catálogo ISCAR Turning Tools.

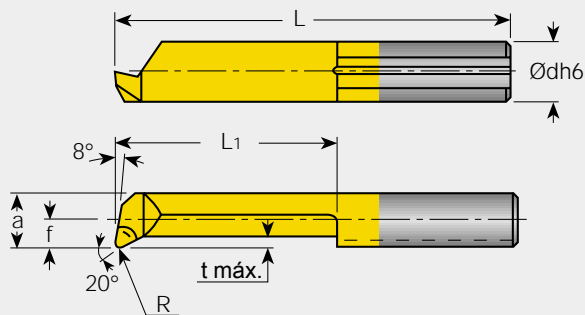
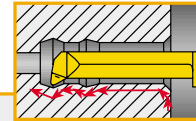
⁽¹⁾ Sólo para Ø6mm.